



The G-QRP Club

The Limerick Sudden 40m Transmitter Kit



Circuit design – George Dobbs G3RJV

PCB design – Rex Harper W1REX

Kit – Graham Firth G3MFJ

Manual – G3RJV and G3MFJ



Founded in 1974, the G-QRP Club is the largest QRP Club in the world. The club exists to promote interest and growth in low power amateur radio communication (5 watts or less). Membership is open to any licensed radio amateur or short wave listener anywhere in the world.

The club publishes a quarterly journal called SPRAT, which is sent free to members. SPRAT contains many circuits, technical hints and ideas for QRP construction projects, together with club news, contest and award information and other items of interest to QRP operators. SPRAT is an exclusive QRP journal and contains much practical information in each issue. The club operates a club sales department where components are available at special prices to club members. We also publish QRP books which are available to members.

If you are not a member, and would like to find out more, please look at www.gqrp.com. For a sample SPRAT and a membership form, please send your name and address to our membership secretary:

**Daphne Newsum G7ENA, 33 Swallow Drive, Louth, LN11 0DN
membership@gqrp.co.uk**

Please mention where you saw this information

Transmier Overview

The Limerick Sudden Transmier is a simple circuit for a reliable QRP transmier. Although crystal controlled, the oscillator stage (T1) is a Variable Crystal Oscillator (VXO). The crystal supplied is a fundamental frequency crystal on 7.030MHz, the QRP calling frequency on the 40 metre band, although other frequencies are available for the CW end of this band. No4ce that an inductor (L1) and a variable capacitor (VC1) have been added in series with the crystal and ground. These induc4ve and capaci4ve elements allow some shi6ing of the frequency.

The oscillator output is coupled via C4 to a 2N3904 Driver stage (T2). TR1 forms the RF (radio frequency) load for the stage. It is also a coupling transformer to drive the power amplifier. The transformer is wound on an FT37-43 core; a ferrite core for broadband coupling. The primary winding is 25 turns of 30 s.w.g. enameled wire. (Gold) The secondary winding is 5 turns of the red wire wound over the centre of the primary winding. The value of the resistance in the emier of T2 determines the amount of drive available to T3 and hence the output power of the transmier. A preset poten4ometer (VR1) is placed in series with R6 and acts as a DRIVE control.

The NPN 2N3906 transistor (T4) is used as a Key Switch to key the transmier. This keys both the oscillator and the buffer/driver (T1 and T2). In many QRP transmier designs it is common to leave the oscillator free running and to key later stages. This is because keying an RF oscillator can result in a "chirpy" CW note. However, T1 is a crystal controlled oscillator and no such chirp occurs. Keying both stages overcomes the problem of oscillator break-through when the oscillator is s4ll running in the receive mode.

SW1 is a NET switch that enables the oscillator to run without keying the transmier. It provides 12 volts for the oscillator and D1 prevents this voltage reaching T2. This facility allows the oscillator to be heard in the receiver so that the VXO signal can be adjusted to a desired frequency or aligned with a desired sta4on signal. "NeGng" is standard prac-4ce when a separate transmier and receiver are being used; it is also called "spoGng" in North America.

T3 is the transmier power amplifier (the Final). This is a simple Class C amplifier biased by the drive voltage from TR1. The output load is provided by L2, an RF choke. A zener diode (ZD1) offers protec4on for the output transistor should the transmier be inadvertently operated without an antenna or into a short circuit. A clip-on heat sink keeps the transistor cool. C6 couples the RF output to a seven element Low-Pass Filter based on the W3NQN filter data, with enhanced² harmonic filtering.

The capacitor C7 leads to the transmier-receiver break-in circuit popularized by W7EL in his "Op4mised Transceiver" design. It is a simple method of sharing the same antenna by a transmier and receiver without damage to the receiver during transmission or significant loss of signal from the transmier. Some mu4ng of the signal fed to the receiver is achieved by the circuit T5, T6 and T7. The mu4ng circuit is such that when a receiver is connected to the transmier, 12 volts must be connected to the transmier to hear signals. The mu4ng is most effec4ve when the covers are on the transmier and receiver.

Building the Transmier

You will have noticed that this is a rather unusual kit. It has a printed circuit board without any holes. We call it "Limerick Construction" because it was designed by Rex Harper, W1REX, of Limerick, Maine. It is a surface mounted board in that the components are mounted on the surface of the board, although the components used are "through-hole" parts. This allows for ease of construction and easy correction of any errors. The main board also has the front and back panels for the transmier. They are scored and can be snapped off the main board. We suggest you smooth the snapped off edges with emery paper or an emery board. The component parts are soldered to the top surface of the board using the leads that would go through the board on a conventional printed circuit board. The interconnections between the mounting pads are ready made but hidden by the black screen printed overlay. The designation of all the parts is printed next to the appropriate pads. Each section of the transmier (OSCILLATOR, DRIVER, FINAL, LOW-PASS FILTER and KEY SWITCH) is also marked on the board. The MUTE circuit components are mounted on the back panel. Any references to top, boom, left and right assume that the board is held with the printed text the correct way, with the G-QRP Club logo in the centre right. Top is actually the Rear of the finished board, and boom is, of course, the Front.

It does help to set out all the components in the order of designation. i.e. C1, C2 etc. The best way is to use a small piece of polystyrene to hold the individual parts. If you are going to use this idea for semiconductors, a piece of aluminium foil wrapped round the polystyrene will prevent any static damage. Double check the capacitor values—there is a lot of difference between 101 and a 104 capacitor!

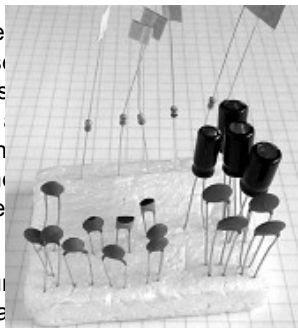

The building of the transmier does entail winding four coils on toroid cores (TR1, and L4, L5 and L6), and a choke for the PA wired on a pig-nosed binocular core (L2). The cores are the small rings that look like miniature "Polo Mints". L1 and L3 are pre-wound chokes (coils) that look like fat resistors. Winding the coils is not difficult; it just requires a little care and the accurate counting of the number of turns. There is ample guidance in the pages of this manual. It is a good idea to wind TR1 before beginning to add any other components to the board. It is the most difficult of the hand-wound coils as it has two windings, a tuned winding and a smaller link winding.

TR1 is wound on the FT37-43 core. This is the black core - the one without the yellow coating. The primary winding has 25 turns of the gold wire. There is guidance as to how to wind these on the next page. Each time the wire passes through the hole of the core counts as one turn. The turns should be laid side by side and occupy about three-quarters of the circumference of the core. The link winding is 5 turns of the red wire wound over the centre of the main winding. Placement of the link winding is not too critical - just guess the centre position.

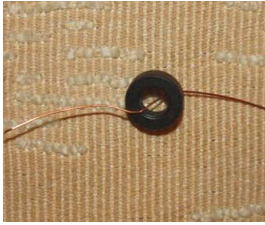

Winding toroidal coils is easy. It just requires patience and care. TR1 uses the black core with the gold wire for the main winding. The 25 turns require 15" of wire. Each time the wire passes through the hole (including the first time) it counts as ONE turn. Hold the core firmly with one hand and

thread the wire through with the other hand, laying the windings side by side. Tighten the wire after each turn for a neat coil.

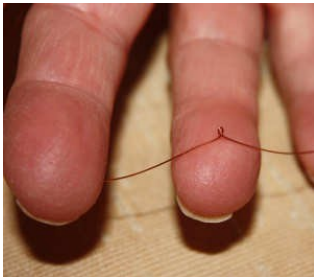
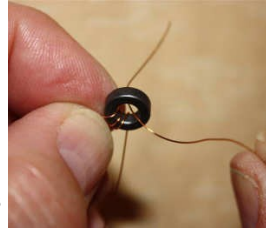

Sometimes if the wire gets twisted and forms a loop it results in a kink. Untwist the wire carefully. Trying to pull out the kink can snap the wire. Complete the 25 turns. They should occupy about three-quarters of the circumference. The 5 turn link winding, using red wire, is added over the centre of the main winding. Guess the centre, it is not really critical



When the windings have been made, trim the ends of the wires to about 1cm. The wire is coated with enamel insulation. About 5mm of each wire should be tinned with solder prior to making the connections. The enamel coating on the wire supplied is designed to melt when the soldering iron is applied. This does require quite a bit of heat. The best method is to form a blob of solder on the soldering iron tip. Apply the tip to the very end of the wire and wait until the enamel melts and the solder flows onto the copper wire. This can take up to 20 seconds. Then move the wire through the blob until you get the required 5mm or so tinned. It's best not to breathe in the smoke given off during this process.

TR1 is mounted vertically in the centre of four pads. The primary (larger) winding is soldered to the top right pad and the secondary (smaller) winding is soldered to the top left pad. The link (5 turn) winding is soldered to the other two pads.



The transmitter is built in two sections; the first being the oscillator section as far as R7. This includes the OSCILLATOR, the DRIVER and the KEY SWITCH. These are then tested before the rest of the stages are added.

Begin by soldering the transistors T1, T2 and T4 to the appropriate pads. The shape of the transistors marked on the board indicates their orientation. They must be placed the correct way round. To enable a secure solder connection of the parts, the leads are bent into an "L" shape for additional contact to the pads on the board.



Add the resistors as far as R9 and the capacitors C1 to C5, C8 and C9, C10 and C11. Capacitor C11 is an electrolytic capacitor and must be connected the correct way round. The negative lead (marked with a series of dashes) goes to the boom pad of the two pads designated for C11. C8 should be bent to be flat against the board as otherwise it may foul the key jack later.



When the resistors and capacitors are in place, the socket for X1 (quartz crystal), L1, D1 and RV1 should be added in their appropriate places. The socket for X1 is a 3-way strip and although we only use the outer 2 pins we will connect all three pins to the pads on the circuit board. The diode D1 pads have a bar marking to correspond to the band on the diode. This diode is very similar to ZD1 – need a magnifying glass to be sure that you have the correct diode.



The front panel

The front panel holds the variable tuning capacitor (TUNE), the net switch (NET SW) and the key jack socket (KEY). These should be fitted, and we suggest that the wiring for these is added as well. Solder these at the component ends first, we will solder the main board ends later.

The tuning capacitor

The tuning capacitor is a two-section polyvaricon type but only the section with the smallest capacitance is used. There are markings (rather small) to indicate the capacitance of each section. A = 14 pF, O = 60 pF and G = Ground. We only require the O and G connections. The "A" solder tag can be cut short (but not removed) to avoid corrosion. 2 off 3cm lengths of wire (yellow (O) and black (G)) for the tuning capacitor should be soldered on the capacitor.

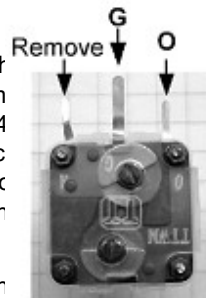

The tuning capacitor is mounted to the front panel using the small screws provided. It is mounted face downward.

The key jack socket

The socket is a 3.5mm socket to be used with a 3.5mm mono jack plug, so one of the connections, (which is a switch contact), is unused. It is a good idea to cut off the unwanted solder tag to avoid confusion. The ground tag should be to the outer edge. The wires for this will be soldered to the main board first, and connected to the jack after the panel is fixed.

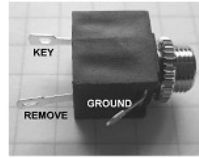

The NET switch

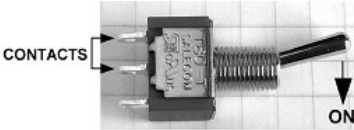

NET SW is a small toggle switch that requires two wires to be joined to the SW1 pads on the main board. Which wire goes to which pad is not important as this is a simple on/off switch. Use the top two contacts on the switch for the wires. When the switch lever is pointing downwards a connection is made between these two contacts. The normal position of the lever when using the transmitter is upwards. 2 pieces of wire (blue and orange, 10 cm long) should be soldered to the net switch, and then twisted together over their full length. North American builders who seem to like their switches upside down compared to European switches may wish to use this switch with VFO on being up!

Now, the LED (light emitting diode) can be mounted on the panel. This fits into a small hole marked "SIG" for signal because the diode to there to glow whenever a signal is being transmitted.



On the inside of the front panel, either side of the SIG hole, there is a double pad and a single pad. The negative side (-) of the LED is connected to ground at the single pad. The positive side of the LED is connected to the double pad nearest the hole. The outer pad, marked "LED" is connected with a wire to the LED pads to the right of R10 on the main board. The longest lead of the LED is the positive lead. To mount the LED, push it into the SIG hole and, using pointed pliers, gently bend the leads in an arc to reach the desired pads.

The finished front panel should look like this –



Now remove the insulation completely from two 2cm pieces of the black wire, and solder one end of each piece of bare wire to the KEY pads on the main board. Be careful you don't catch your fingers on these when they are stuck up in the air!

Add the side cheeks



This is a good time to solder the “side cheeks” into place either side of the main board. These are designed as fixing plates for the enclosure. Adding the side cheeks at

this point does mean that the fixing of the front and back panels of the receiver is much easier. Attaching the side cheeks does require a really hot soldering iron bit and plenty of solder. These are not identical so make sure you have the right ones at the correct sides – see the picture below to check. We should, at this point, recommend our SBSS clamps, which are designed for this purpose - both the side cheeks, and the front panel are easily fixed this way.

If you don't use our clamps, then we suggest that you begin with a large blob of solder at one end to fix the position. Attempt to get the side cheek as near vertical as possible and exactly in line with the main board. When you are happy with this, you may put a few blobs of solder on the narrow pads on the length of the board. Be careful near the blue variable resistor, the plastic easily melts when touched by the iron!

When you have fixed these, the front panel can be soldered in place – after connecting the variable capacitor and net switch leads. The O (yellow) goes to the left-hand pad nearest to the centre of the front of the board, and the G connection (black) goes to the right-hand (nearer the edge) pad.



This picture shows that done, and the correct vertical position of the side panels although they have not been soldered into place yet.



Like the side cheeks the front panel is soldered to the main board. This panel, unlike the side cheeks, overlaps the base board. The base board should be put in the gap between the soldered tracks at the bottom of the front panel. This picture shows the correct position of the front panel against the base. Again, we suggest that you use the “one blob” technique underneath the board to get the panel aligned correctly and vertical. Add a second blob when you are happy with the alignment,

then you should put a few good blobs of solder along the top side of the board for extra strength.

Finally for this stage, connect the two bare wires to the key jack – this picture shows that done. The ground connection (see diagram—top of page 7) should be nearest the case



Complete circuit diagram

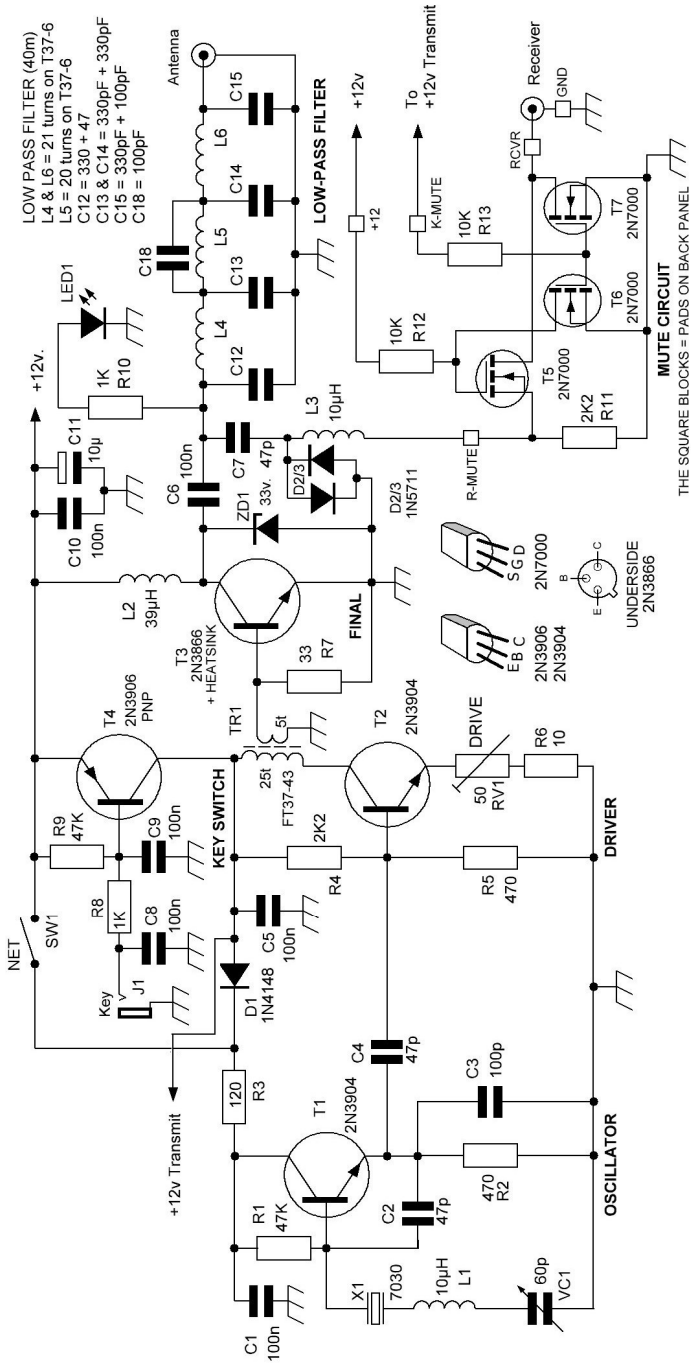

Tes9ng the first sec9on

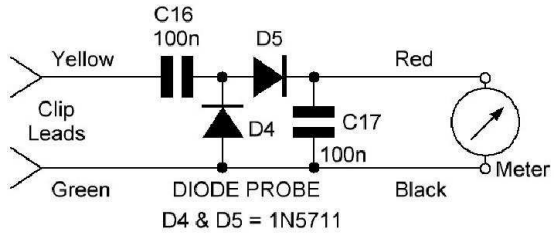
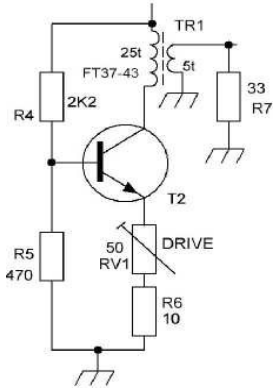

Yellow Clip Lead to top of R7
 Green Clip Lead to ground
 Red lead with 4mm plug to Meter +
 Black lead with 4mm plug to Meter -

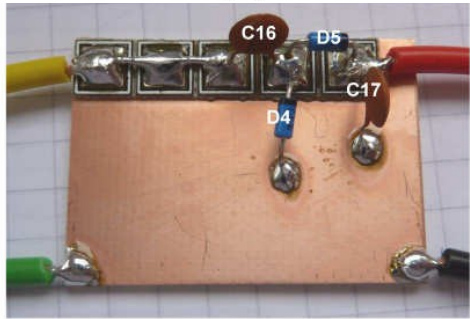

Tes4ng the transmier at this stage requires a Diode Probe. All the parts are provided for making such a probe as shown in the picture.

The diode probe is built “Manhattan-style” by attaching a strip of five pads to the top left-hand corner of the printed circuit board material using super glue.

The components are surface mounted as shown. The three left-hand pads are joined using an off-cut from one of the trimmed component leads.

Flexible wire in red, black, yellow and green is supplied. The yellow and green leads are terminated with crocodile clips and the red and black leads are terminated with 4mm plugs



(the standard plug used in test meters). If your meter uses a different size of plug, then you will have to obtain these yourself. The placement of the four leads is shown in the circuit drawing. Later the diode probe will be converted into a basic wattmeter to measure the final transformer output.

For those not familiar with 4mm plugs, the centre of the metal insert contains a grub screw to secure the end of the wire. A small screw driver pushed up the centre of the metal insert is used to clamp the end of the wire as shown. The metal insert is then pushed into the plastic housing of the plug, wire being placed in line with the slot in the plastic housing. The insert is now pushed until the end of the plug is as far out as it will travel. This does take force! Pushing the end of the insert against a firm surface will help. You might need a screwdriver to push in the final bit of the metal insert.

The crocodile clips are easier to attach to the ends of the yellow and green wire. Prize the clip open a little and slide off the plastic covering. The wire can be soldered to the clip and held in place by the crimps at the end. Remember – Push the plastic covering onto the wire before soldering the wire in place.



The clip is chromium plated and soldering will be much easier if the area to take the solder is roughed a little with emery paper or the

edge of a sharp knife.

The red and black leads are plugged into the positive (+) and negative (-) inputs of the meter. The yellow lead is clipped on the left side of R7 (the pad connected to the output of TR1) and the green lead is connected to the other (grounded) end of R7. The meter should be set on a range that will indicate 10 volts DC.

Testing the Transmitter

Having made the RF probe, the first section of the transmitter is now ready for testing, so make a temporary supply lead using red & black wires – to the +12 and ground pads, respectively, in the centre of the board. We suggest that you make these about 20cm long. As a precaution, you should turn the blue drive preset fully anti-clockwise before you power the board – don't forget to insert the crystal!

When you are happy with all the connections (a check that all the parts are in the correct places is useful at this stage). Apply 12 Volt power to the board: +12v to the red wire, and the negative to the black wire.

Firstly, check the oscillator. If you press the net switch, the oscillator only will run, and this can be found around 7.030MHz on a suitable receiver. The tune control should vary the frequency from around 7.027MHz to 7.031MHz.

[NOTE – there is scope for experiment with the value of the series inductor L. Increasing the value of this will give an increase in frequency range, however, this may be at the expense of oscillator stability. The value supplied with the kit is a safe value. See the modification notes on page 17]

Secondly, check the keying and driver stages.



A 3.5mm mono jack plug is supplied with the kit to fit the KEY jack socket. Attach this to a Morse key or two pieces of wire that can be shorted to simulate a Morse key.

Depressing the key or joining the wires should give an indication of a few volts in the meter connected to the RF probe. The Oscillator, Driver and Key Switch stages are all working if the meter shows an output voltage. Around 3 volts is a reasonable value, and you should be able to change this with the drive preset. Remember to turn this back to the fully anti-clockwise position before you move on to the next step.

Now, the rest of the transmier.

The final amplifier

Firstly, wind the coil L2. This is 5 turns on a FT43-2402 b toroid. Each turn goes through both holes of the core, and should end up with it looking like this.



It is helpful to insert this and the other components in the sec4on marked "FINAL" (ZD1, R10, C6 and C7) before adding the final amplifier transistor (T3) (2N3866). ZD1 must be connected the correct way round. The boom pad of the ZD1 placement shows a bar marking; this corresponds to the bar (or ring) near one end of the zener diode.

Trim the transistor leads to about 10mm and bend the end 3mm of the transistor leads to form a "foot" that will lay flush with the pads. The best direc4ons for the foot, assuming the tab on the transistor case points upwards, are emier upwards, collector downwards and base to the le6. Refer to the base connec4on diagram on the circuit schema4c. Using pointed pliers manipulate the leads un4l each foot rests on the required pad. Tin the pads and the leads and solder them in place. The heatsink is applied to the transistor by placing a screwdriver blade in the gap and twis4ng it to open the vanes. The heatsink should now fit over the transistor casing. The screwdriver is removed to allow the heatsink to clamp firmly on the sides of the transistor.

The next step is to solder a 10cm length of yellow wire to the LED pad on the main board (just to the rear of the +12v power pad, connect the other end of this to the LED pad on the front panel. Tuck this wire in 4dily as you can see on the picture of the main board and front panel below. The diodes D2 & D3 should be soldered into place - the diode D2/3 pads have a bar marking (like ZD1) to show the way to mount them. Finally solder the "fat resistor" sized inductor, L3 into place.

The low-pass filter

The low-pass filter coils (L4, L5 & L6) are wound on the yellow cores using the gold wire. L4 and L6 have 21 turns, L5 has 20 turns. These require 14" (35cm) of wire for each coil. Wind as TR1 with one pass through the core being one turn. L5 has on less turn (20) than L4 and L6 (21 each) so wind L5 first and lay aside so that it won't be confused with the others. 35cm of wire is easily enough for each coil. The windings on each core should occupy about three-quarters of the circumference.

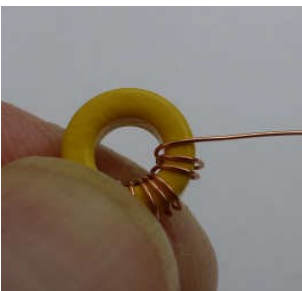



Nearly all the capacitors in the filter are actually two in parallel as the correct values are not commercially available. We suggest that you parallel these pairs first as shown here, before fitting them. A good plan is to mount C12 - C15, and C18, then mount L5, followed by L4 and L6.

Here is a picture of the complete board so far.

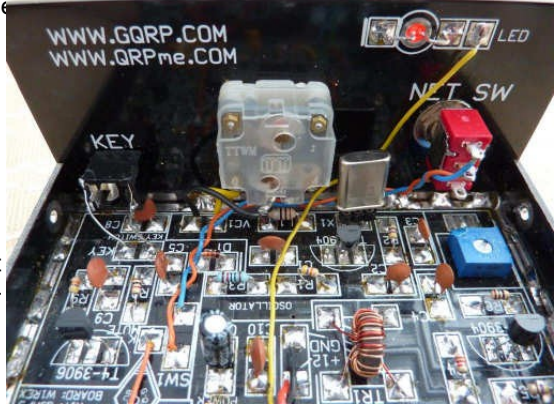

The layout of the printed circuit board. This shows the wiring between the pads

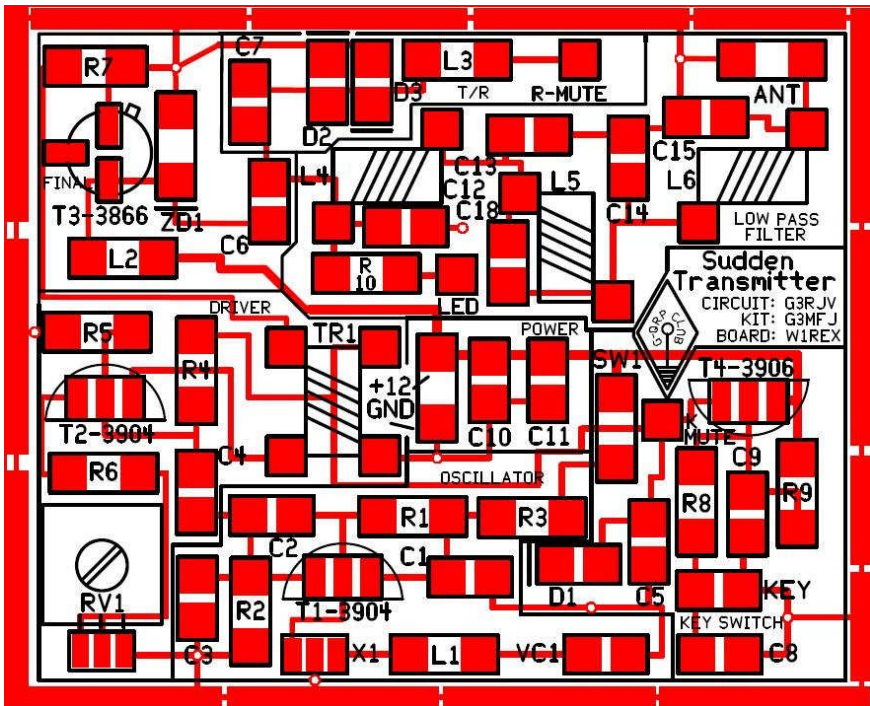

The back panel.

Firstly, mount the three sockets on the back panel – the antenna socket, the receiver aerial socket and the power socket.

The antenna sockets

The antenna socket (ANT) is a single hole phono socket, as is the RECEIVER socket. They require two wires to be joined to the ANT pads on the main board and we will connect these in a moment.



The power socket



The POWER socket also has two connections that connect to the main board and it is vital to get these the correct way round. Again, we will connect these shortly.

The receiver mounting

The components for the receiver mounting section are mounted inside the back panel, and you should now fit these. Solder the resistors into place first, followed by the transistors. It is best to keep the lead length of these parts short if possible.

The next job is to connect the rear panel to main board. Firstly, you need to cut several lengths of wire. The first three are on the back panel and are as follows:

RCVR on the back panel connects to the centre of the RECEIVER phono socket – use 3cm of orange wire for this.

GND on the back panel connects to the ground tag on the RECEIVER phono socket – use 1½cm of bare wire for this.

Solder a 10cm length of red wire to the +12V tag on the back panel but do not connect the other end yet.

Now cut the other four pieces as follows and solder these to the pads on the main board:

R-MUTE on the main board – use a 9cm length of green wire for this.

K-MUTE on the (boom of club logo) on the main board – use a 10cm length of orange wire for this.

ANT on the main board – use two 9cm lengths of wire – black and blue, the black (ground) connection goes to the left-hand pad and the blue (antenna connection) goes to the right-hand pad. Y

You should already have two pieces of wire connected to the +12V and GND tags of the main board that we used for testing. Cut these to 9cm long.

Wiring the back panel to the main board.

Now, if you place the rear panel behind the main board, you can connect the other end of all the wires – green to R-MUTE, orange to K-MUTE, black to the outer solder tag of the antenna socket, and the blue wire to the centre connection. Finally after stripping the ends of the two red wires, twist them together and solder them both to the centre pin of the power socket.

This picture shows that done.

(NB This picture is of the 30m version of the kit so the toroids L4/5/6 are different)

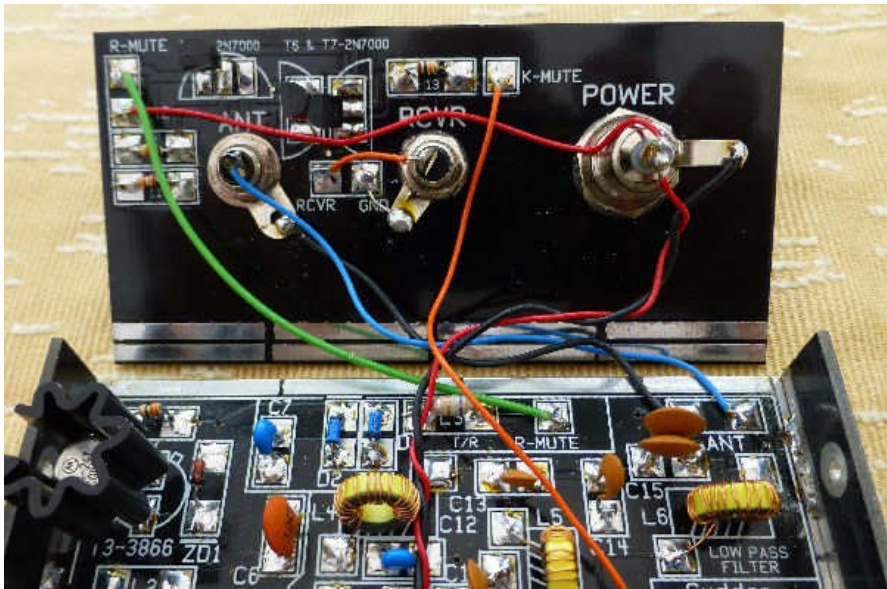

Finally, having finished the wiring to the back panel, you should solder the back panel in place using the same method that you used for the front panel. Be careful when soldering near the wires as the insulation is easily damaged by the soldering iron. There is enough length to move them out of the way of the iron.

Testing the transmitter

The first step is to convert the RF Probe into a simple SWR Meter.

The original diode probe has three 150 Ohm large resistors added to the three lead pads and ground. These resistors connected in parallel form a 50 Ohm load for the transmitter. Do not attempt to transmit without either a 50 Ohm load or connecting the output to a matched antenna.

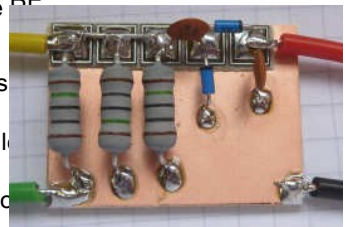

Connect the yellow clip lead to the centre of the ANT socket and the green clip to the ground of the ANT socket and the red and black leads to a voltmeter. Connect the 12 volt supply, leaving the NET SW switch upwards, and press the Morse KEY down. Read the output voltage. The

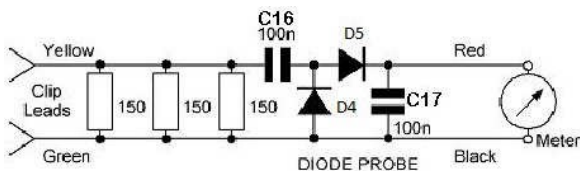

voltage is the peak to peak measurement. If you are going to use the RF wameter o6en, then we suggest that you replace the yellow and green leads with a shor4sh piece of 50 Ohm coax terminated in a Phono (RCA)plug. The inner

conductor should go where the yellow lead was connected, and the screen to the copper where the green wire was connected.

The output in was = r.m.s voltage²divide by 50.

The calcul4on is simple:

- Voltage reading (peak to peak) divide by 2 = the peak voltage
- The peak voltage is mul4plied by 0.707 = the r.m.s. voltage.
- The r.m.s. voltage mul4plied by itself = r.m.s. voltage²
- Divide this by 50 (the load resistor value) for the RF power output in was.

A suitable 2.1mm power plug is supplied with the kit – the centre pin is +ve and the outer connection is -ve. Do not get these reversed as there is no reverse polarity protection in the transmier.

The transmier should produce about 1 to 2 was. The Drive control (RV1) may be used to adjust the final output. Although the 2N3866 final amplifier transistor is quite rugged and is protected by ZD1, it is possible to destroy the transistor by either overdriving it, or by transmiGng for more than a few seconds into an incorrect load. With this in mind a spare 2N3866 is provided with the kit – do not destroy this as well! We suggest you begin below 2 was and increase the output to around 2 was maximum. Try for an output voltage on the test meter of some 25 to 28 volts. One to two was on 40 metres represents a useful amount of QRP transmier power. If you turn up the drive control up too much, the output power will start to go down - and this should be avoided as it will produce a bad output signal. Remember to use the transmier with the NET SW in the upward (off) position. Pressing the switch downwards switches power to the oscillator only. Use this position to find the frequency of the transmier on the receiver. This may be used to find a particular frequency or to “net” the transmier to another station. The transmier output is 50 Ohms and the transmier should be used into a 50 Ohm antenna (e.g. a dipole) or via an Antenna Tuner to match the 50 Ohms to the antenna.

Finally – the case

The case parts should now be soldered together – the important point here is that the sides must be at right-angles to the top. Again, use the single blob technique un4l you are satisfied with the angles – it is beer if you do not solder right up to the front of the lid as the case overlaps the front to give a hooded effect, and if you solder right up to the front, the case may not fit as well.

What next? - Possibilities for experiment

Radio amateurs would not be radio amateurs if they didn't want to experiment, so here are a couple of things that you may wish to experiment with. Remove the transmitter power, and be careful that you do not destroy anything in the transmitter whilst you are changing parts! If you are not sure of your own abilities, then ask a more experienced constructor to do it for you.

The VXO

The VXO circuit is a “sure fire” circuit that will always work, but there is a possibility to increase the shift range by altering the value of L3. If you increase L3, then the polyvaricon VC1 will move the frequency more. Possible disadvantages are that either the oscillator will stop oscillating at some parts of the tuning control travel, and/or, the oscillator will chirp when the TX is keyed. You will possibly need the use of the station receiver to test this. You will probably have to unfasten VC1 and move it aside to change any of these parts. The polyvaricon has a second section - this has a capacitance shift of 6 to 160pF. You may wish to try using the second section. When you have altered any values, take a careful listen on a good receiver to ensure that you have a stable non-chirping transmission. Be careful! Another change is that you could try two identical crystals in parallel—this can considerably increase the VXO shift.

The RX tuning circuit

This circuit is a simple and reasonably effective way of considerably reducing the amount of transmitted signal that gets back to the receiver. Because it is a simple circuit, and there is no “mute” signal down a separate wire to the receiver, then the tuning may appear to not be working very well. In fact, without it, the received signal from the TX would be considerably louder. This is another point at which you could do some experimenting and that is by replacing C7 with a smaller fixed capacitor in parallel with a trimmer. There is just room to do this—but you will have to be very careful with the soldering iron, and avoid touching nearby parts. Aim, with the two capacitors, for a value when the trimmer is mid-position, to be a value around the supplied (and now removed) C7. The trimmer should be adjusted with the TX powered up, but not transmitting. Adjust the trimmer for the maximum received signal strength of a weak signal on the receiver - the weaker the better. It should not be adjusted when you are either receiving, or transmitting.

Again - be very careful - this is a modification for experienced constructors only.

We do not recommend that you touch or alter parts in the output of the PA. If you change anything, then you may reduce the harmonic filtering and then there could be unwanted or even illegal radiations from the transmitter.

Improvement to the SIG LED indicator

In a recent SPRAT article, Paul M0XPD suggested that the indication by the SIG LED can be improved, especially if there isn't a DC path at the Antenna connection. He suggested that an ordinary diode, for example a 1N4148 diode, be wired in inverse parallel to the LED on the front panel. This should be connected so that the +ve end of this (the one with the indicating band) should be wired to the double pad on the front panel, and the other end, to the single pad. An extra 1N4148 has been added to the parts bag in case you wish to try this.

| | Value | Markings |
|-------------------|--------------------------|---------------------------------------|
| Resistors | | |
| R1 | 47k | Yellow, purple, orange, gold |
| R2 | 470 | Yellow, purple, brown, gold |
| R3 | 120 | Brown, red, black, black, brown |
| R4 | 2k2 | Red, red, red, gold |
| R5 | 470 | Yellow, purple, brown, gold |
| R6 | 10 | Brown, black, black, gold |
| R7 | 33 | Orange, orange, black, gold |
| R8 | 1k | Brown, black, red, gold |
| R9 | 47k | Yellow, purple, orange, gold |
| R10 | 1k | Brown, black, red, gold |
| R11 | 2k2 | Red, red, red, gold |
| R12 | 10k | Brown, black, orange, gold |
| R13 | 10k | Brown, black, orange, gold |
| R14 | 150 | Brown, green, black, black, brown |
| R15 | 150 | Brown, green, black, black, brown |
| R16 | 150 | Brown, green, black, black, brown |
| Capacitors | | |
| C1 | 100nF | 104 |
| C2 | 47pF | 47 |
| C3 | 100pF | 101 |
| C4 | 47pF | 47 |
| C5 | 100nF | 104 |
| C6 | 100nF | 104 |
| C7 | 47pF | 47 |
| C8 | 100nF | 104 |
| C9 | 100nF | 104 |
| C10 | 100nF | 104 |
| C11 | 10uF | 10uF (the -ve side is plainly marked) |
| C12 | 377pF (330 + 47pF) * | 331 + 47 |
| C13 | 660pF (330 + 330pF) * | 331 + 331 |
| C14 | 660pF (330 + 330pF) * | 331 + 331 |
| C15 | 430pF (330 + 100pF) * | 331 + 101 |
| C16 & 17 | 2 x 100nF | 104 (for RF probe) |
| C18 | 100pF | 101 |
| | * these values are 2 | capacitors in parallel – see text |
| Inductors | | |
| L1 | 10uH | Brown, black, black, silver |
| L2 | BN43-2402 binocular core | Pig nose – 5 complete turns 30SWG |
| L3 | 10uH | Brown, black, black, silver |
| L4 | T37-6 | Yellow/black – 21 turns |
| L5 | T37-6 | Yellow/black – 20 turns |
| L6 | T37-6 | Yellow/black – 21 turns |
| TR1 | FT37-43 | Black – 25t (30SWG) + 5t (27SWG) |

Semiconductors

| | | |
|-------------|----------------------------|---------------------------------------------------------------------------------------|
| T1 | 2N3904 | Oscillator |
| T2 | 2N3904 | Driver |
| T3 | 2N3866 (4-247 CG9949) | PA (spare included) |
| T4 | 2N3906 | Keyer |
| T5 | 2N7000 | RX series mute |
| T6 | 2N7000 | voltage inverter |
| T7 | 2N7000 | RX parallel mute |
| D1 | 1N4148 | For net switch |
| D2 | 1N5711 | RX parallel mute |
| D3 | 1N5711 | RX parallel mute |
| D4 | 1N5711 | Probe detector |
| D5 | 1N5711 | Probe detector |
| ZD1 | 33v zener diode (BZX55C33) | PA protector |
| LED | Output indicator | |
| Extra diode | 1N4148 | This is a second diode in case you wish to try the SIG LED indicator improvement (see |

Other parts

| | | |
|---------------------|---------------------------|------------------------------------------|
| RV1 | 50 Ohm | Drive control preset |
| VC1 | 60pF | Tuning |
| SW | miniature toggle switch | Net switch (may be a 2 tag part) |
| J1 | 3.5mm mono jack socket | Key jack |
| J2 | Phono/RCA socket | Antenna |
| J3 | Phono/RCA socket | Antenna to receiver |
| X1 | Crystal | 7.030MHz HC49U wire lead crystal |
| Socket | Crystal socket | 3 SIL sockets |
| 35mm knob | For VXO tuning capacitor | |
| Toroids | For L4, L5 & L6 | 3 x T37-6 - yellow/black |
| Toroid | For T1 | FT37-43 - black |
| Pig-nose toroid | For L2 | BN43-2402 |
| Magnet wire | 30 SWG | Gold coloured |
| Magnet wire | 27 SWG | Red coloured |
| PVC wire | 6 colours of wire | Red, Black, Orange, Yellow, Blue & Green |
| Heatsink | For PA transistor | |
| Power socket | Panel mounting 2.1mm | |
| Power plug | 2.1mm | |
| 4 feet | for case | |
| Key plug | 3.5mm mono plug | |
| Blank PCB | For probe | |
| 5 MESquares | For probe | Black, Red, Yellow, Green |
| Extra flex wire | For probe | Black, Red |
| 4mm plugs | For probe | Yellow, Green |
| Min crocodile clips | For probe | |
| Screws | 4 off self-tapping screws | For fixing the case to the base |

The finished transmier

NB - this is a picture of the 30m version of the kit



© G-QRP Club 2010/11/12/13/14/15/16

V2.8 September 2016